

AG 2.50" - 12.00" Automatic Balancing Valve

NuTech Model AW with Groove X Flange Adaptors

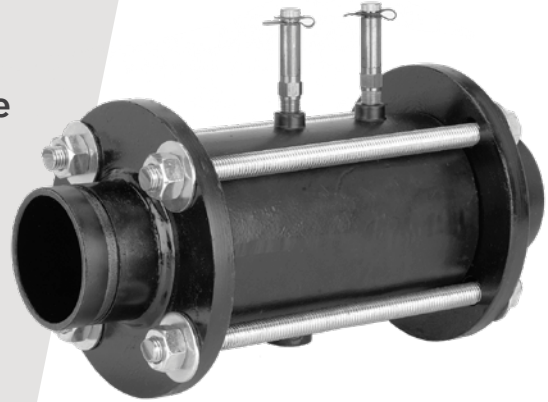

MODEL AW/AG PRODUCT INFORMATION

PART	MATERIALS
Body (Wafer)	Cast Steel
End Connection	Wafer body compatible with ANSI Class 150 or 300 lb. Flanges
Cartridge(s)	300 Series Stainless Steel Wear Surfaces with Stainless Steel Spring
Groove X Flange Adaptors	150# Plate with Schedule 40 Steel Pipe, (2x Model GF)
Gasket	1/8" Thick 150# Non-asbestos, Ring
Threaded Rods	Steel Zinc, CR 3 ROHS Compliant
Nuts	Zinc Plated, Heavy Hex Nut

SPECIFICATIONS

Function:	Automatic Balancing Valve
Sizes:	2.50" - 14.00"
Ratings:	Pressures to 600 PSIG (4140 kPa) Temperatures to 250° F (120° C)
Pressure Range:	Low = 2-32 PSID (2.50" - 14.00") High = 5-60 PSID (2.50" - 14.00")
Accuracy:	± 5% of flow rate

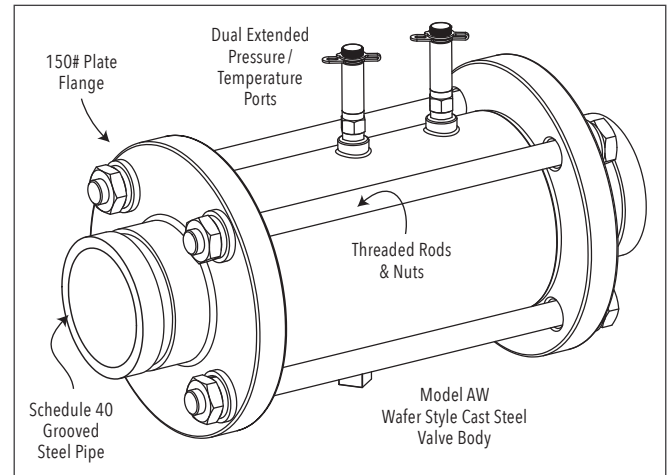

CONNECTIONS

MODEL	SIZE	INLET CONNECTION	OUTLET CONNECTION
AG - 250	2.50" 65 mm	Groove X Flange Adaptor	Groove X Flange Adaptor
AG - 300	3.00" 80 mm	Groove X Flange Adaptor	Groove X Flange Adaptor
AG - 400	4.00" 100 mm	Groove X Flange Adaptor	Groove X Flange Adaptor
AG - 500	5.00" 125 mm	Groove X Flange Adaptor	Groove X Flange Adaptor
AG - 600	6.00" 150 mm	Groove X Flange Adaptor	Groove X Flange Adaptor
AG - 800	8.00" 200 mm	Groove X Flange Adaptor	Groove X Flange Adaptor
AG - 1000	10.00" 250 mm	Groove X Flange Adaptor	Groove X Flange Adaptor
AG- 1200	12.00" 300 mm	Groove X Flange Adaptor	Groove X Flange Adaptor

Threaded Rods, Nuts & Washers are supplied with Valve

AG 2.50" - 12.00" Automatic Balancing Valve

NuTech Model AW with Groove X Flange Adaptors

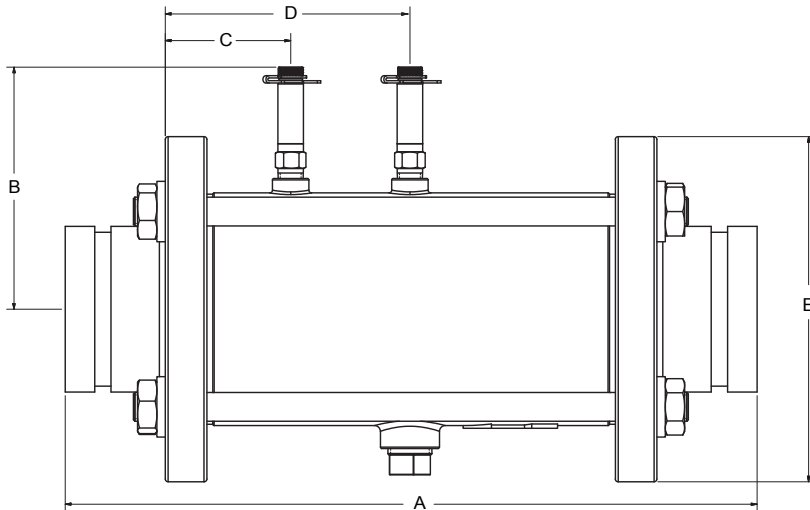

NOMINAL DIMENSIONS, WEIGHTS & FLOWS

MODEL	SIZE		A	B	C	D	E	WEIGHT		Max.No. Cartridges	Maximum GPM (lps) Control Range PSID (kPa)	
	in	mm						lbs	kg		2-32 (14-221)	5-60 (34-414)
AG-250	2.50"	65	in 12.07	4.58	2.19	4.29	7.00	24.00	10.89	1	80 (5.0)	120 (7.6)
		mm 306.58	116.33	54.50	108.97	177.80						
AG-300	3.00"	80	in 15.00	5.26	2.75	5.38	7.50	32.84	14.90	1	135 (8.5)	170 (10.7)
		mm 381.00	133.60	69.72	136.65	190.50						
AG-400	4.00"	100	in 15.81	6.22	3.39	7.46	9.00	51.26	23.25	2	270 (17.0)	340 (21.4)
		mm 401.57	158.00	85.99	189.36	228.60						
AG-500	5.00"	125	in 18.25	6.61	3.45	7.04	10.00	58.59	26.58	3	405 (25.5)	510 (32.1)
		mm 463.55	167.90	87.50	178.69	254.00						
AG-600	6.00"	150	in 18.41	7.05	3.22	7.18	11.00	74.00	33.57	4	540 (34.0)	680 (42.8)
		mm 467.61	179.10	81.66	182.25	279.40						
AG-800	8.00"	200	in 23.25	8.00	3.16	5.91	13.50	175.52	79.61	7	945 (59.5)	1190 (75.0)
		mm 590.55	203.20	80.26	150.11	342.90						
AG-1000	10.00"	250	in 23.25	9.30	3.16	4.91	16.00	261.32	118.53	11	1485 (93.6)	1870 (118.0)
		mm 590.55	236.22	80.26	125.48	406.40						
AG-1200	12.00"	300	in 27.38	10.60	3.75	5.75	21.00	367.25	166.47	15	2025 (128.0)	2550 (161.0)
		mm 695.45	269.24	95.25	146.05	533.40						

*Nominal Dimensions & Weights shown above are not to be used for construction purposes unless first certified by the Factory.

ORDERING DESIGNATION

AG - 250 - L - XX

MODEL _____
AG-250 (Shown)

BODY SIZE _____
2.50" (Shown)

CONTROL RANGE _____
L = 2-32 PSID H = 5-60 PSID

ACCESSORIES _____
*Optional Accessories Designations

AVAILABLE OPTIONS

*Optional Accessories are an extra charge and not included in the standard model price.

Accessory Designations:

BA	Buy American Construction	BX	Boxing with Tag
BB#	Use Union End Ball Valve for Drain Valve - Specify Size: BB1 or BB2 with 0.50" MNPT Tailpiece	CC	Connection Charge
		DV-050	Drain Valve (3.00" - 6.00")
		HT	Hanging Tag (Plastic)
		PX	Extended Pressure/Temperature Vent