

## AW Automatic Balancing Valve

NuTech's AW Automatic Balancing Valve incorporates a Wafer style Cast Steel body. The removable flow Cartridge(s) are factory set to automatically limit the GPM to within  $\pm 5\%$  of the specified flow. Valve is shipped with Threaded Rods and Nuts for use with customer supplied companion Inlet and Outlet flanges. Standard features include dual Extended Pressure/Temperature Ports.



### PRODUCT INFORMATION

PART	MATERIALS
Body (Wafer)	Cast Steel
End Connection	Wafer body compatible with ANSI Class 150 or 300 lb. Flanges ( <i>Customer Supplied</i> )
Cartridge(s)	300 Series Stainless Steel Wear Surfaces with Stainless Steel Spring
Threaded Rods	Steel Zinc, CR 3 ROHS Compliant
Nuts	Zinc Plated, Heavy Hex Nut

### SPECIFICATIONS

Function:	Automatic Balancing Valve
Sizes:	2.50" - 14.00"
Ratings:	Pressures to 600 PSIG (4140 kPa) Temperatures to 250° F (120° C)
Pressure Range:	Low = 2-32 PSID (2.50" - 14.00") High = 5-60 PSID (2.50" - 14.00")
Accuracy:	$\pm 5\%$ of flow rate

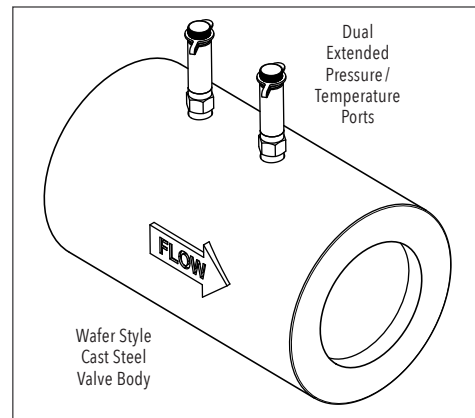

Model AW is shipped with Threaded Rods, Washers and Nuts, Customer Supplies Companion 150 or 300 lb. Flange End Connections.

### CONNECTIONS

MODEL	SIZE	INLET CONNECTION	OUTLET CONNECTION
AW - 250	2.50" 65 mm	*Customer Supplied Flange	*Customer Supplied Flange
AW - 300	3.00" 80 mm	*Customer Supplied Flange	*Customer Supplied Flange
AW - 400	4.00" 100 mm	*Customer Supplied Flange	*Customer Supplied Flange
AW - 500	5.00" 125 mm	*Customer Supplied Flange	*Customer Supplied Flange
AW - 600	6.00" 150 mm	*Customer Supplied Flange	*Customer Supplied Flange
AW - 800	8.00" 200 mm	*Customer Supplied Flange	*Customer Supplied Flange
AW - 1000	10.00" 250 mm	*Customer Supplied Flange	*Customer Supplied Flange
AW - 1200	12.00" 300 mm	*Customer Supplied Flange	*Customer Supplied Flange
AW - 1400	14.00" 350 mm	*Customer Supplied Flange	*Customer Supplied Flange

\*Companion Flanges are Customer Supplied, Threaded Rods, Nuts & Washers are supplied with Valve

## AW 2.50" - 14.00" Automatic Balancing Valve

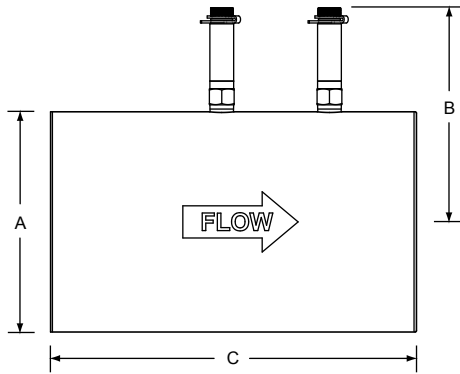

Model AW is shipped with Threaded Rods, Washers and Nuts, Customer Supplies Companion 150 or 300 lb. Flange End Connections.

### NOMINAL DIMENSIONS, WEIGHTS & FLOWS

MODEL	SIZE			A	B	C	WEIGHT		Max.No. Cartridges	Maximum GPM (lps) Control Range psid (kPa)	
	in	mm					lbs	kg		2-32 (14-221)	5-60 (34-414)
AW-250	2.50"	65	in	4.30	4.80	5.82	13.0	5.9	1	80 (5.0)	120 (7.6)
			mm	109	122	148					
AW-300	3.00"	80	in	5.00	5.15	8.78	22.0	10.0	1	135 (8.5)	170 (10.7)
			mm	127	131	223					
AW-400	4.00"	100	in	6.80	6.00	9.60	35.0	15.9	2	270 (17.0)	340 (21.4)
			mm	173	152	244					
AW-500	5.00"	125	in	7.60	6.50	10.00	56.0	25.4	3	405 (25.5)	510 (32.1)
			mm	193	165	254					
AW-600	6.00"	150	in	8.50	6.80	10.16	67.0	30.4	4	540 (34.0)	680 (42.8)
			mm	216	173	258					
AW-800	8.00"	200	in	11.00	8.00	11.00	81.0	36.7	7	945 (59.5)	1190 (75.0)
			mm	279	203	279					
AW-1000	10.00"	250	in	13.30	9.30	11.00	121.0	54.9	11	1485 (93.6)	1870 (118.0)
			mm	338	236	279					
AW-1200	12.00"	300	in	15.90	10.60	11.00	157.0	71.2	15	2025 (128.0)	2550 (161.0)
			mm	404	269	279					
AW-1400	14.00"	350	in	17.60	11.50	11.00	221.0	100.0	19	2585 (162.0)	3230 (203.0)
			mm	447	292	279					

Nominal Dimensions & Weights shown above are not to be used for construction purposes unless first certified by the Factory.

### ORDERING DESIGNATION

**AW - 250 - L - XX**

MODEL \_\_\_\_\_  
*AW-250 (Shown)*

VALVE BODY SIZE \_\_\_\_\_  
*2.50" (Shown)*

CONTROL RANGE \_\_\_\_\_  
*L = Low 2-32 psid (Shown), H = High 5-60 psid*

ACCESSORIES \_\_\_\_\_  
*\*Optional Accessories Designations Below*

#### AVAILABLE OPTIONS

\*Optional Accessories are an extra charge and not included in the standard model price.

#### Accessory Designations:

BB#	Use Union End Ball Valve for Drain Valve - Specify Size: BB1 or BB2 with 0.50" MNPT Tailpiece	Bx	Boxing with Tag
		CC	Connection Charge
		DV-050	Drain Valve (3.00"- 6.00")
		HT	Hanging Tag (Plastic)
		PX	Extended Pressure/Temperature Vent