

## MF

### 2.50" - 6.00" Manual Balancing Valve

NuTech's MF Manual Balancing Valve offers manual balancing and shut off. Valve features a Cast Steel Venturi Flow Element with a precisioned machined throat providing measurement accuracy of  $\pm 3\%$  of flow rate. Mounted on the discharge is a ductile iron Lug Type Butterfly Valve with release handle and an Adjustable Flow Positioning Plate with locking nut. ANSI Class 125/150# flanged End Connections. Standard features include dual Extended Length Pressure/Temperature Ports and Hanging I.D. Tag.

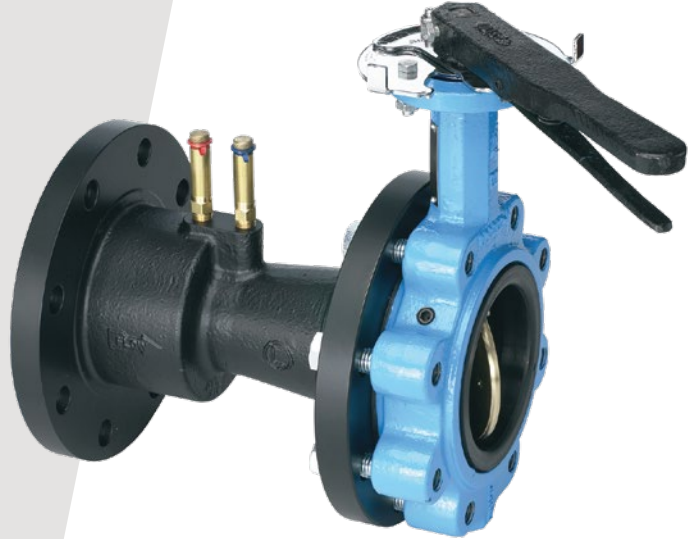

#### PRODUCT INFORMATION

PART	MATERIALS
Venturi	ASTM A-216 Grade WCB
Butterfly Valve	Ductile Iron A536 65-45-12
Disc	Aluminum Bronze B148 C954
Stem	Stainless Steel 416 A582
Seat	EPDM with Phenolic Backing
Bushing	Teflon/Fiberglass Backed
Seal	EPDM
End Connections	ANSI Class 125/150# Flanged
Bolts	(ASTM) A307 Grade B
Metering Ports	Extended Length Pressure/Temperature

#### SPECIFICATIONS

Function:	Manual Balancing Valve and shut off valve
Sizes:	2.50" - 6.00"
Ratings:	Pressures to 200 PSIG (1380 kPa) Temperatures to 250° F (120° C)
Accuracy:	$\pm 3\%$ of flow rate

Adjustable Flow Positioning Plate with locking nut.



Butterfly Valve handle with release

Inlet detail of Venturi Flow Element with precisioned machined throat

#### CONNECTIONS

MODEL	SIZE	INLET CONNECTION	OUTLET CONNECTION
MF - 250L	2.50" 65 mm	ANSI Class 125/150# Flanged	Butterfly Valve
MF - 300L	3.00" 80 mm	ANSI Class 125/150# Flanged	Butterfly Valve
MF - 400L	4.00" 100 mm	ANSI Class 125/150# Flanged	Butterfly Valve
MF - 500L	5.00" 125 mm	ANSI Class 125/150# Flanged	Butterfly Valve
MF - 600L	6.00" 150 mm	ANSI Class 125/150# Flanged	Butterfly Valve

*Venturi & Valve Mounting Bolts are supplied.*

## MF 2.50" - 6.00" Manual Balancing Valve

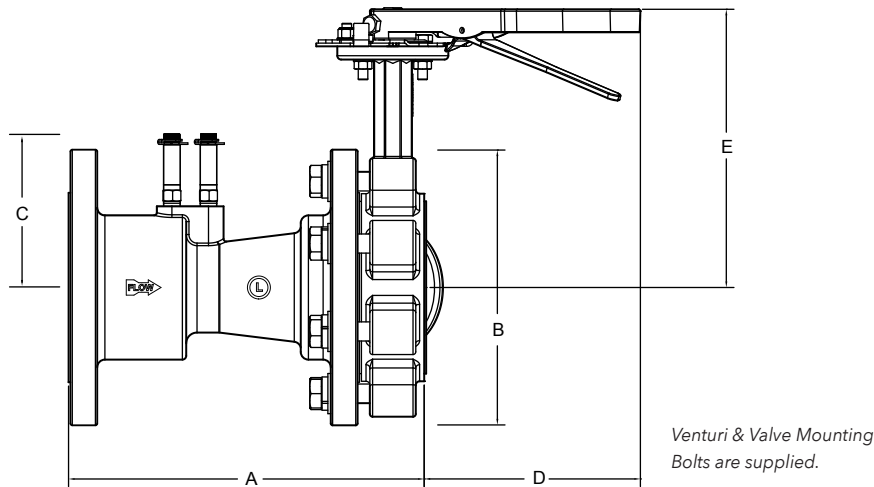

### NOMINAL DIMENSIONS, WEIGHTS & FLOWS

MODEL	SIZE			A	B	C	D	E	Wgt	
	in	mm							lbs	kg
MF-250L	2.50"	65	in	8.75	7	4.2	9.13	8.13	32	14.51
			mm	222.25	177.8	106.65	231.9	206.5		
MF-300L	3.00"	80	in	9.78	7.5	4.54	9.13	8.38	38	17.23
			mm	248.41	190.5	115.31	231.9	212.85		
MF-400L	4.00"	100	in	11.5	9	5.02	9	9.13	55	24.94
			mm	292.1	228.6	127.5	228.6	231.9		
MF-500L	5.00"	125	in	13.13	10	5.53	9	9.63	79	35.83
			mm	333.5	254	140.46	228.6	244.6		
MF-600L	6.00"	150	in	14.73	11	6.04	8.88	10.13	92	41.73
			mm	374.14	279.4	153.41	225.55	257.3		

Nominal Dimensions & Weights shown above are not to be used for construction purposes unless first certified by the Factory.

### ORDERING DESIGNATION

**MF - 250 - L - XX**



#### AVAILABLE OPTIONS *Please note \*Optional Accessories are an extra charge and not included in the standard model price.*

Accessory Designations:	BA	Buy American Construction	HT	Hanging Tag (Plastic)
	BX	Boxing with Tag	PX	Extended Pressure/Temperature Vent
	CC	Connection Charge		