

MG 2.50" - 6.00" Manual Balancing Valve

NuTech Model MF with Groove X Flange Adapters

MODEL MF/MG PRODUCT INFORMATION

PART	MATERIALS
Venturi	ASTM A-216 Grade WCB
Butterfly Valve	Ductile Iron A536 65-45-12
Disc	Aluminum Bronze B148 C954
Stem	Stainless Steel 416 A582
Seat	EPDM with Phenolic Backing
Bushing	Teflon/Fiberglass Backed
Seal	EPDM
End Connections	Groove X Flange Adapter, 150# Plate Flange with Schedule 40 Steel Pipe
Bolts	(ASTM) A307 Grade B
Metering Ports	Extended Length Pressure/Temperature
OPTIONAL Gasket	1/8" Thick 300# Non-asbestos, Ring (Consult Factory)

SPECIFICATIONS

Function:	Manual Balancing Valve and shut off valve
Sizes:	2.50" - 6.00"
Ratings:	Pressures to 200 PSIG (1380 kPa) Temperatures to 250° F (120° C)
Accuracy:	± 3% of flow rate

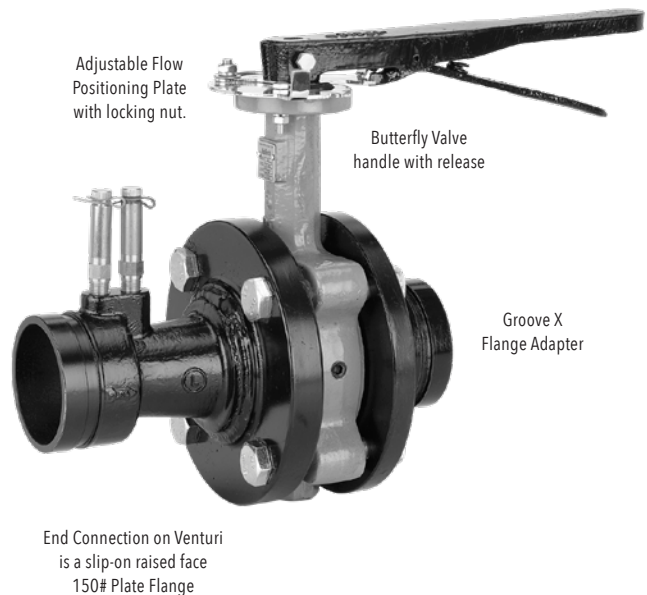

CONNECTIONS

MODEL	SIZE	INLET CONNECTION	OUTLET CONNECTION
MG - 250L	2.50" 65 mm	Groove X Flange Adapter	Raised Face 150# Plate Flange
MG - 300L	3.00" 80 mm	Groove X Flange Adapter	Raised Face 150# Plate Flange
MG - 400L	4.00" 100 mm	Groove X Flange Adapter	Raised Face 150# Plate Flange
MG - 500L	5.00" 125 mm	Groove X Flange Adapter	Raised Face 150# Plate Flange
MG - 600L	6.00" 150 mm	Groove X Flange Adapter	Raised Face 150# Plate Flange

Flange Adapter Mounting Bolts are supplied.

MG 2.50" - 6.00" Manual Balancing Valve

NuTech Model MF with Groove X Flange Adapters

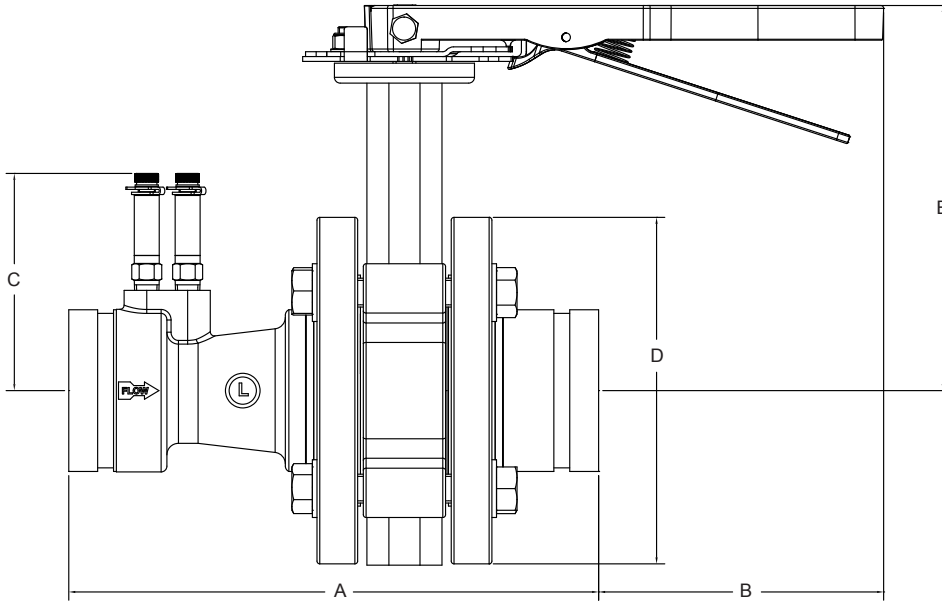

NOMINAL DIMENSIONS, WEIGHTS & FLOWS

MODEL	SIZE			A	B	C	D	E	WEIGHT	
	in	mm							lbs	kg
MG-250L	2.50"	65	in	10.87	6.22	4.36	7.00	8.10	23.5	10.66
			mm	276.10	157.99	110.74	177.80	205.74		
MG-300L	3.00"	80	in	11.47	6.17	4.70	7.50	8.34	28.4	12.88
			mm	291.34	156.72	119.38	190.50	211.84		
MG-400L	4.00"	100	in	13.62	5.91	5.18	9.00	9.09	43	19.50
			mm	345.95	150.11	131.57	228.60	230.89		
MG-500L	5.00"	125	in	14.64	5.97	5.69	10.00	9.60	73	33.11
			mm	371.86	151.64	144.53	254.00	243.84		
MG-600L	6.00"	150	in	17.05	5.21	6.20	11.00	10.11	89.9	40.78
			mm	433.07	132.33	157.48	279.40	256.79		

*Nominal Dimensions & Weights shown above are not to be used for construction purposes unless first certified by the Factory.

ORDERING DESIGNATION

MG - 250 - L - XX

MODEL _____
 MG-250L (Shown)
 VALVE BODY SIZE _____
 2.50" (Shown)
 CONTROL RANGE _____
 L = Low
 ACCESSORIES _____
 *Optional Accessories Designations

AVAILABLE OPTIONS Please note *Optional Accessories are an extra charge and not included in the standard model price.

Accessory Designations: BA Buy American Construction
 BX Boxing with Tag
 CC Connection Charge
 HT Hanging Tag (Plastic)
 PX Extended Pressure/Temperature Vent